

Refrigerated Salad Display VI XA 157M (R0S8.80157S)



SKU: VI XA 157M

Dimensions: 157 × 80 × 129 cm

Weight: 180 Kg

Recomended industries: GENERAL USE

GN Capacity: 18 GN 1/4

Capacity: 520

Lower Temperature (C): +3

Horse Power (HP): 1/2

Higher Temperature (C): +6

Volume (m3): 1.73

Doors: 2.5

Product Description

All refrigerators have insulation polyurethane, 1 shelf per door, magnetic sealing rubbers (Easy to change) and electronic thermostat with automatic defrost.

Product Photos

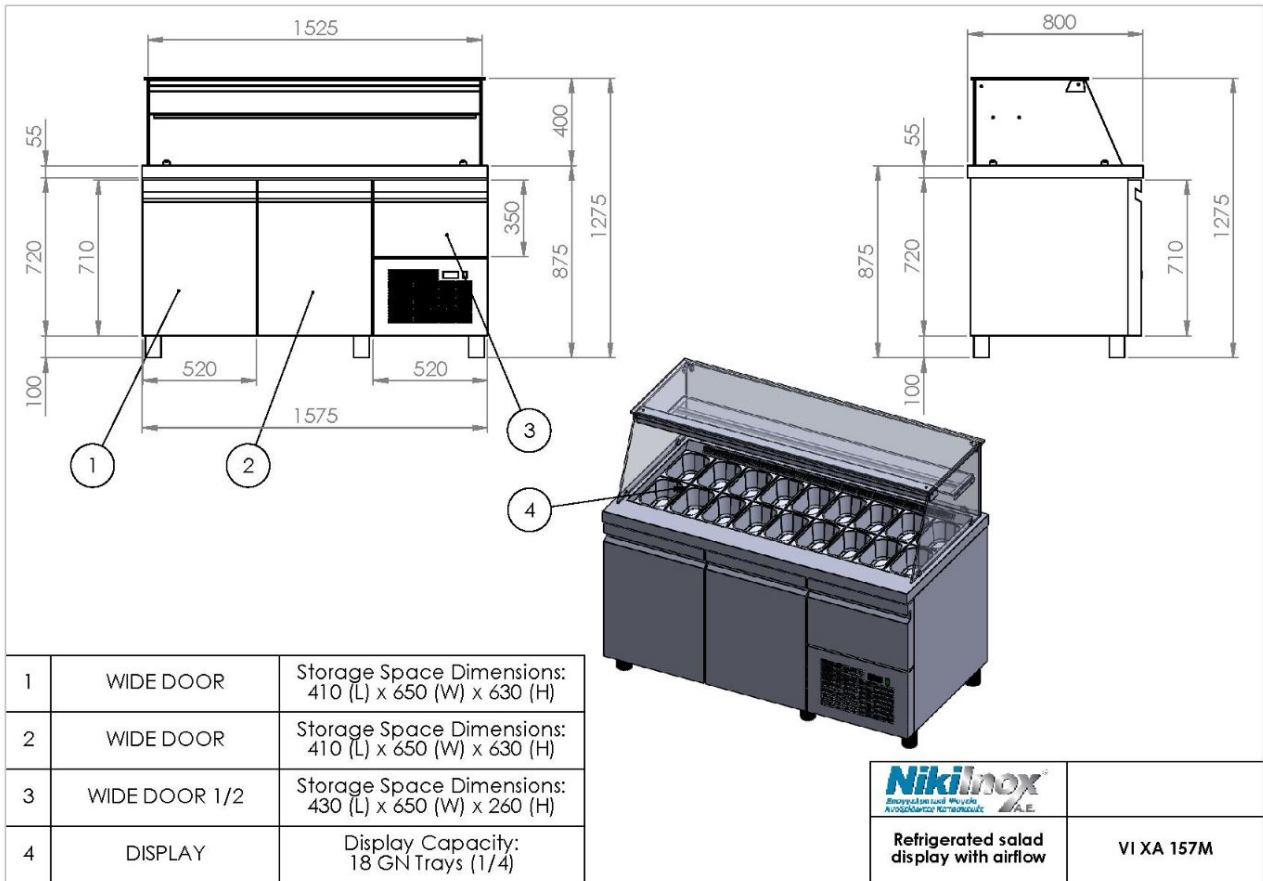

Technical Drawing

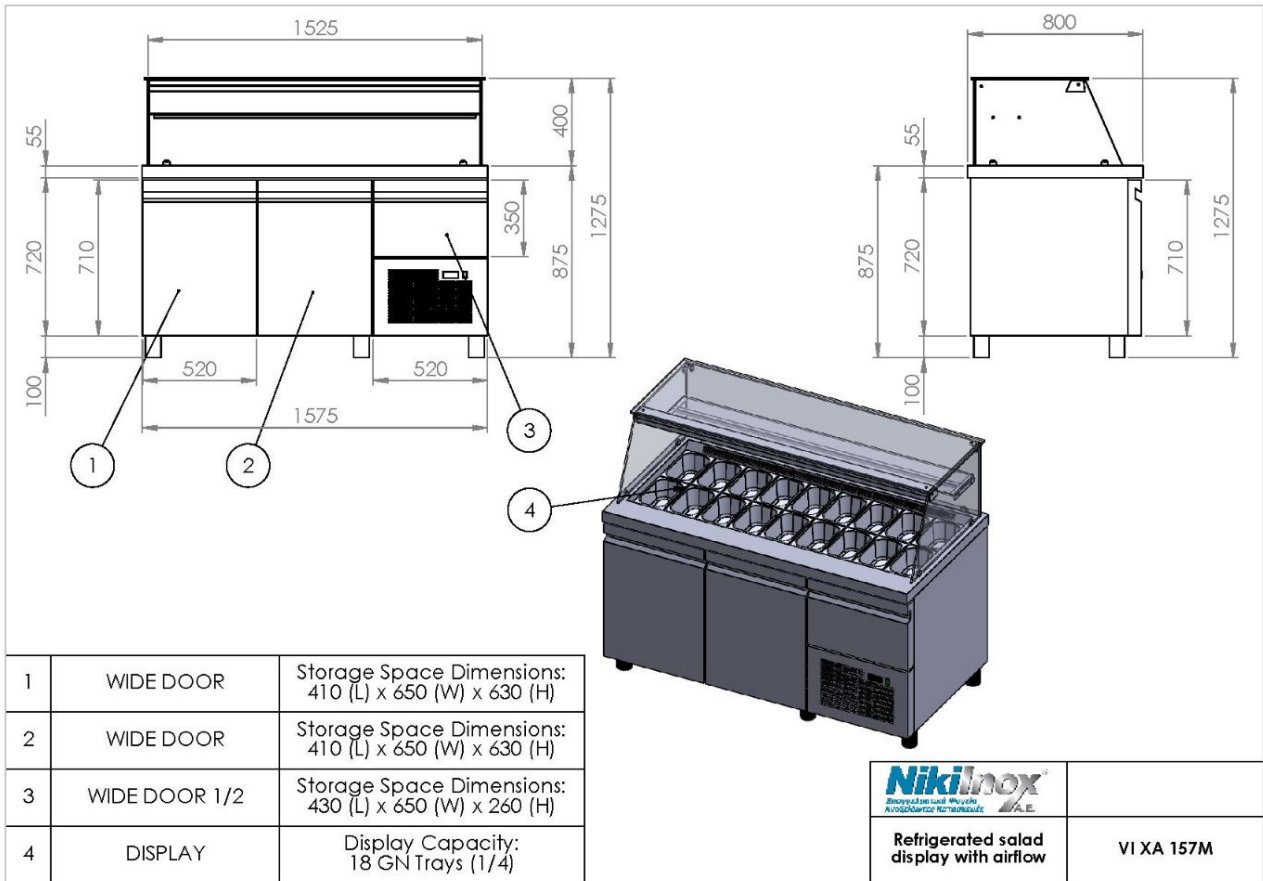

NIKI INOX S.A.

Industrial Area of Thessaloniki

P.O. Box 1056, 57022 Sindos

VAT: 082104633 G.E.MI. No:

38081805000

T: +30 2310 798 696

F: +30 2310 797 920

URL: <https://niki-inox.gr>

E: info@niki-inox.gr

