

Heated display THE ED 179 (H0HC.GN179E)



SKU: THE ED 179

Dimensions: 179 × 70 × 129 cm

Weight: 110 Kg

Power consumption (W): 2100

Volume (m3): 1.57

Product Description

All refrigerators have insulation polyurethane, 1 shelf per door, magnetic sealing rubbers (Easy to change) and electronic thermostat with automatic defrost.

Product Photos

Technical Drawing

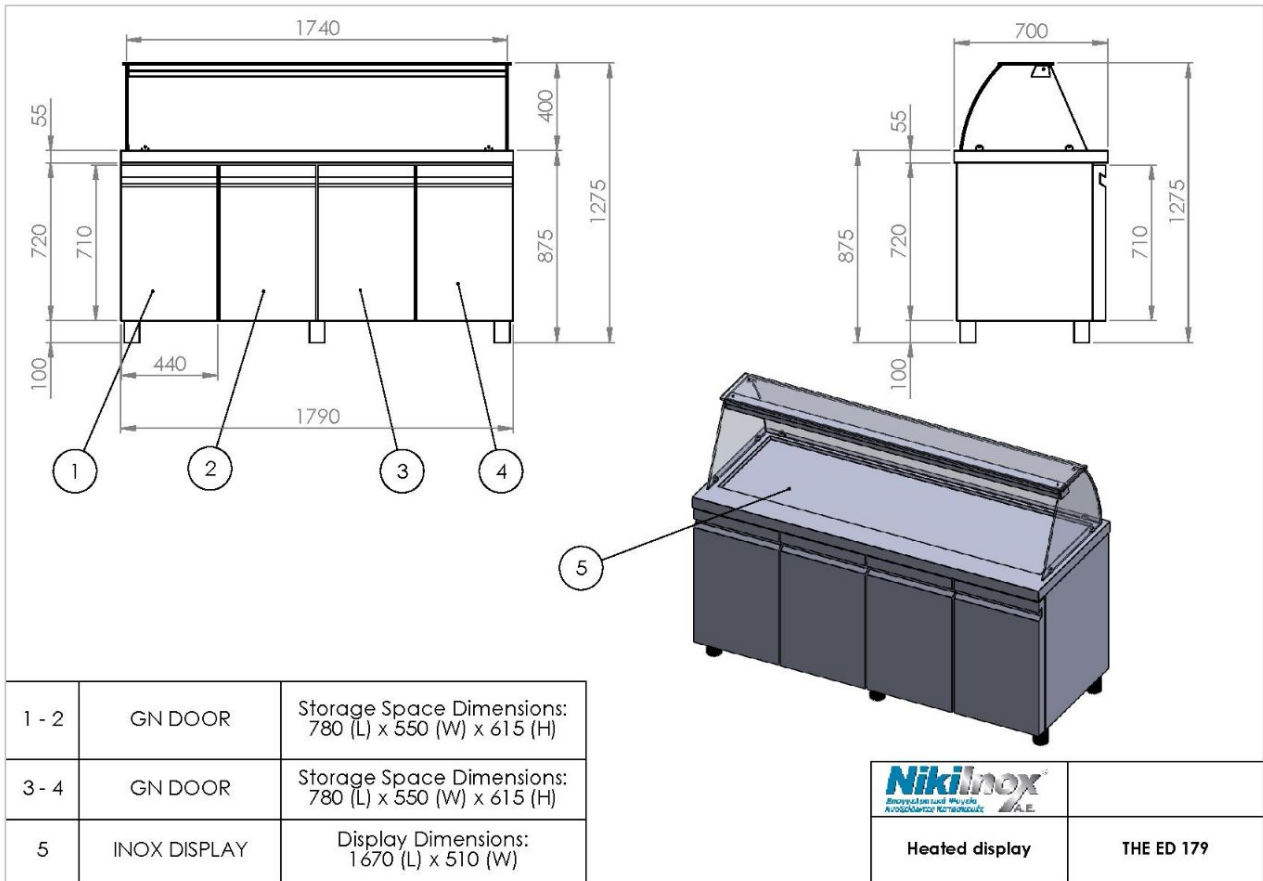

NIKI INOX S.A.

Industrial Area of Thessaloniki
 P.O. Box 1056, 57022 Sindos
 VAT: 082104633 G.E.MI. No:
 38081805000

T: +30 2310 798 696

F: +30 2310 797 920

URL: <https://niki-inox.gr>

E: info@niki-inox.gr

