

## Refrigerated Counter with compressor PA 60 179M (R0PA.60179R.000H)



**SKU: PA 60 179M**

**Dimensions:** 179 × 60 × 88 cm

**Weight:** 140 Kg

**Recommended industries:** STREET FOOD

**Higher Temperature (C):** +8

**Lower Temperature (C):** -1

**Volume (m3):** 0.95

**Capacity:** 460

**Horse Power (HP):** 1/4

**Doors:** 3.5

### Product Description

All refrigerators have insulation polyurethane, 1 shelf per door, magnetic sealing rubbers (Easy to change) and electronic thermostat with automatic defrost.

### Product Photos

## Technical Drawing

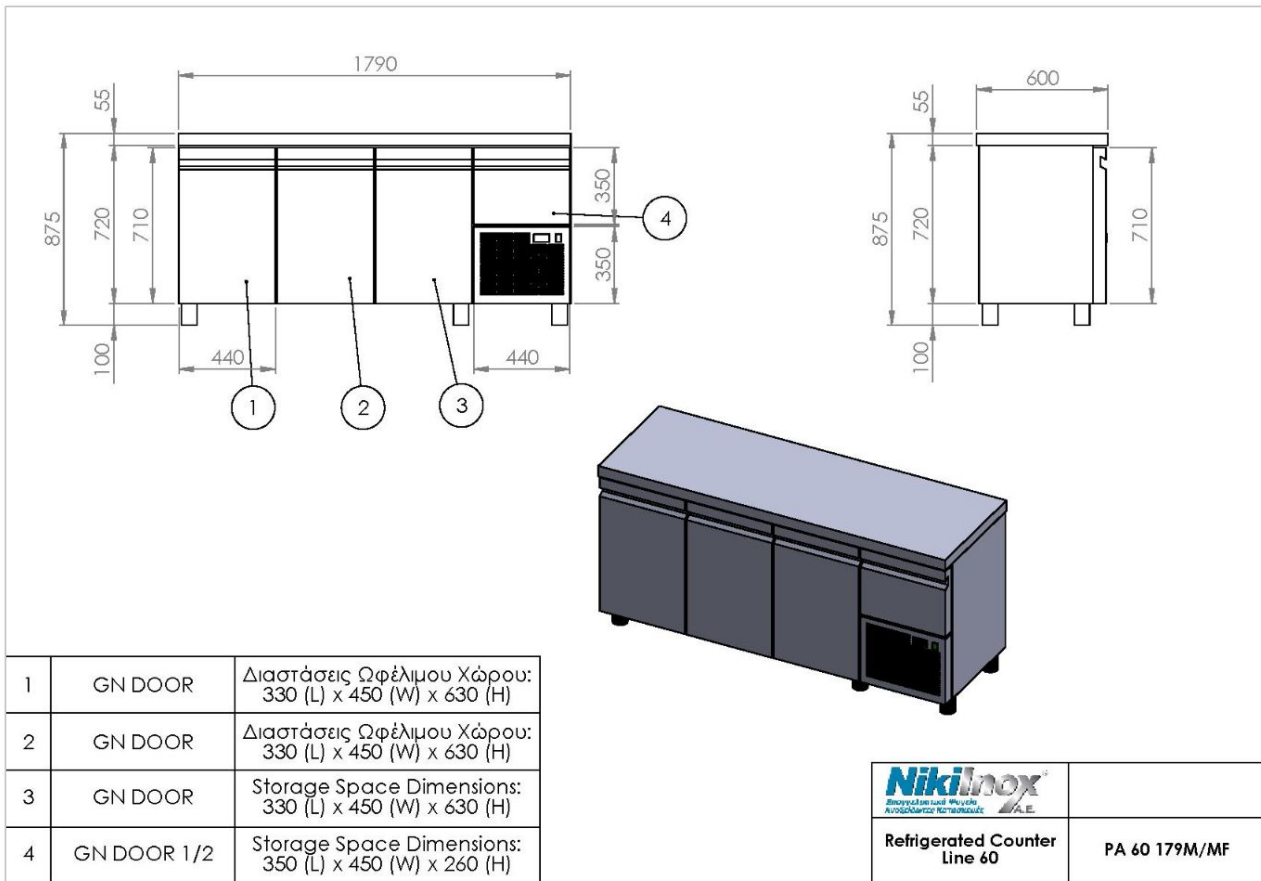

### NIKI INOX S.A.

Industrial Area of Thessaloniki

P.O. Box 1056, 57022 Sindos

VAT: 082104633 G.E.MI. No:

38081805000

T: +30 2310 798 696

F: +30 2310 797 920

URL: <https://niki-inox.gr>

E: [info@niki-inox.gr](mailto:info@niki-inox.gr)