Refrigerated Counter with compressor PA GN 185M (R0PA.GN185R.000)



SKU: PA GN 185M

- **Construction:** Stainless steel AISI 304
- **Ergonomic design** for easy use and maintenance
- **Thermostat:** Built-in electronic thermostat for precise temperature control
- **Defrosting:** Automatic system with electric resistances
- **Functionality:** Buttoned magnetic rubbers, ergonomic handles, full-length telescopic guides
- **Depth:** 700 mm
- **GN 1/1 pan holder**
- **Sheets:** 1 per door
- **Capacity:** 287 L
- **Insulation:** High density polyurethane
- **Arrangement:** Three doors
- **Flexibility:** Door replacement with any of the three types of drawers (upon request)
- **4 Alternatives for the lid:** simple lid, lift-up lid, lid with 30*32 trough or without lid (upon request)
- **Adjustable feet**
- **Cooling:** Forced air circulation system for uniform temperature distribution
- **Eco-friendly refrigerant R290**
- **Temperature adjustment:** External thermometer and thermostat with adjustment from -1°C to +8°C

Dimensions: 185 × 70 × 88 cm

Weight: 127 Kg

Capacity: 458

Higher Temperature (C): +8

GN Trays: 1 (1/1)

Product Description

The professional stainless steel counter-refrigerator **PA GN 185M** is the ideal choice for any modern kitchen that requires **efficient food storage and preservation**.

Made of **high-quality AISI 304 stainless steel**, it combines **durability, elegance and functionality**, meeting the needs of every professional space.

▪ Flexibility in storage & Ergonomics

It has three doors, which ensure **large capacity** and practicality. The **GN 1/1 pan holder** makes it easy to organize your ingredients.

▪ Safe and comfortable to use

The snap-on magnetic rubbers and the **ergonomic handles** offer **safe closing and easy handling**, while the **full-length telescopic guides** in the drawers ensure smooth operation..

▪ Precise temperature control & efficient defrosting

The built-in electronic thermostat offers precise temperature control, while the automatic defrosting system with electric resistances ensures continuous and efficient operation.

▪ Flexibility & Adaptability

Its smart design allows the door to be changed with any of the three drawer types, upon request, covering even the most personalized needs. The adjustable feet allow the height to be adjusted for comfortable placement. In addition, with four alternatives for the lid—simple lid, lift-up lid, lid with 30*32 trough or even without a lid upon request—it offers unsurpassed flexibility.

▪ Sustainability

The use of the **ecological refrigerant R290** underlines our commitment to a **sustainable future**.

With the **PA GN 185M**, you get a **reliable tool** that will upgrade your professional kitchen!

Product Photos



Technical Drawing

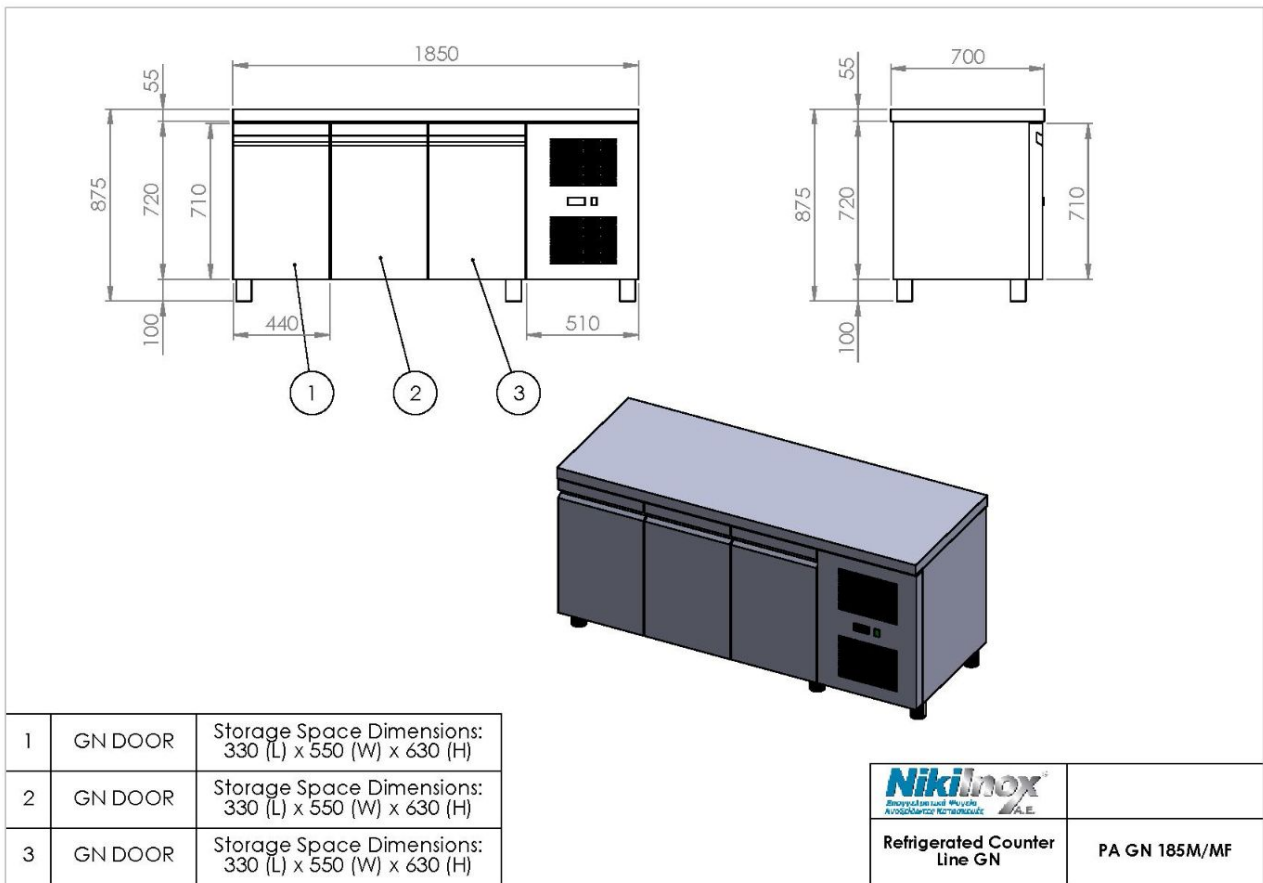

NIKI INOX S.A.

Industrial Area of Thessaloniki

P.O. Box 1056, 57022 Sindos

VAT: 082104633 G.E.MI. No:

38081805000

T: +30 2310 798 696

F: +30 2310 797 920

URL: <https://niki-inox.gr>

E: info@niki-inox.gr